

### Pedigree Problem 3:

To the right is a pedigree for an inherited heart disease. What is the probability that their child F would have the inherited heart disease?

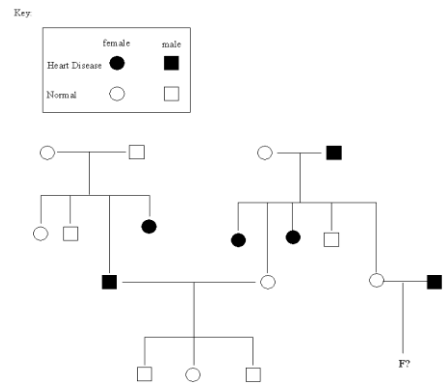

Use the information provided below to create a pedigree. Then answer the question at the end of each description.

- A man and woman marry. They have five children, 2 girls and 3 boys. The mother is a carrier of hemophilia, an X-linked disorder. She passes the gene on to two of the boys who died in childhood and one of the daughters is also a carrier. Both daughters marry men without hemophilia and have 3 children (2 boys and a girl). The carrier daughter has one son with hemophilia. One of the non-carrier daughter's sons marries a woman who is a carrier and they have twin daughters. What is the percent chance that each daughter will also be a carrier?
- The great-great maternal grandmother of a boy was a carrier for color-blindness, an X-linked disorder. His great uncle on his mother's side was colorblind but this great uncle's father was unaffected. The boy's mother has 2 brothers (1 colorblind, 1 unaffected) and 1 sister (unaffected). The boy's grandmother on his mother's side had 1 brother who was colorblind and 3 sisters. Two of these sisters were unaffected and one was a carrier. The boy's great grandmother on his mother's side had 4 sisters. The boy has one unaffected sister and he is colorblind. What is the probability of the boy's sons being colorblind if he marries a non-carrier?
- An unaffected man marries a woman who is a carrier for Duchenne Muscular Dystrophy, which is attributed to an X-linked gene. They have four children, one with Duchenne, one carrier daughter and a daughter and son who are unaffected. The child with Duchenne Muscular Dystrophy dies in childhood. The carrier daughter marries and has three children of her own, two of which are carriers and one of which is unaffected. What is the most likely sex of these two carrier children given the fact that they are unaffected by the X-linked gene?